



**Programa de las
Naciones Unidas
para el Medio
Ambiente**



Distr.
GENERAL

UNEP/OzL.Pro/ExCom/62/28
3 de noviembre de 2010

ESPAÑOL
ORIGINAL: INGLÉS

COMITÉ EJECUTIVO DEL FONDO MULTILATERAL
PARA LA APLICACIÓN DEL
PROTOCOLO DE MONTREAL
Sexagésima segunda Reunión
Montreal, 29 de noviembre al 3 de diciembre de 2010

PROPUESTA DE PROYECTO: CUBA

El presente documento consta de las observaciones y recomendaciones de la secretaría del Fondo sobre la propuesta de proyecto siguiente:

Destrucción

- Proyecto de demostración piloto sobre gestión y eliminación de desechos de SAO

PNUD

DESCRIPCIÓN DEL PROYECTO

Introducción

1. El PNUD, en nombre del Gobierno de Cuba, presentó a la sexagésima segunda reunión una propuesta relativa a un proyecto de demostración piloto sobre gestión y eliminación de desechos de sustancias que agotan el ozono (SAO) a un costo de 792.763 dólares de los EE.UU más gastos de apoyo al organismo por un monto de 59.457 dólares de los EE.UU., en su presentación original. El presente proyecto se presenta de conformidad con la decisión 58/19 y abordará la destrucción de 60,4 toneladas métricas (tm) de desechos de SAO en el país. El Gobierno de Cuba está pidiendo la aprobación del presente proyecto en la sexagésima segunda reunión.

2. En la quincuagésima novena reunión, el Comité Ejecutivo proporcionó fondos para que el PNUD preparase un proyecto de demostración piloto sobre SAO para Cuba. En esa Reunión, se adoptó la decisión de examinar proyectos piloto sobre eliminación de SAO que respondiesen a la decisión XX/7 de la 20ª Reunión de las Partes, en la que se disponía que los proyectos piloto podían abarcar el acopio, el transporte, el almacenamiento y la destrucción de SAO, que se ocupen especialmente de existencias consolidadas con un alto potencial de calentamiento atmosférico (PCA) neto y en una muestra representativa de países que operan al amparo del artículo 5 de diversas regiones. Los miembros subrayaron también que los proyectos de demostración de eliminación de SAO debían ser factibles e incluir métodos para procurar la cofinanciación. Cuba fue uno de los países seleccionados sobre la base de estos criterios.

Antecedentes

3. En la quincuagésima octava reunión del Comité Ejecutivo se examinaron los criterios y las directrices para la selección de proyectos de eliminación de SAO, lo que culminó en la decisión 58/19. En esta decisión se establecieron los fundamentos para el examen y la aprobación de proyectos de demostración sobre la eliminación de SAO. El examen llevado a cabo por la Secretaría se fundamentó en los principios establecidos en esa decisión. La Secretaría deseaba subrayar que aplicó el apartado a) ii) a. de la decisión, en el que se especifica que no se pondrían a disposición fondos para el acopio de SAO. La definición relativa al acopio de SAO se incluyó en un anexo del informe de la quincuagésima octava reunión titulado “definiciones de actividades incluidas en las directrices provisionales para la financiación de proyectos de demostración relacionados con la eliminación de SAO”. El proyecto piloto para Cuba que aquí se presenta se ocupará de las SAO ya acopiadas, así como de cantidades adicionales que se acopien en el marco del programa de incentivos financiado por los países para la retirada de equipo de refrigeración doméstica y de aire acondicionado con miras a promover el rendimiento energético.

4. El presente proyecto piloto procura crear un marco logístico eficaz y rentable para el transporte, el almacenamiento y la destrucción de SAO en Cuba. El proyecto se ocupará de los desechos de SAO que ya se han acopiado y dejará también firmemente establecido un sistema que permita a Cuba encargarse de la destrucción de desechos de SAO que se acopien en el futuro como parte del *Programa Nacional de sustitución total de refrigeradores y equipos de aire acondicionado de alto consumo de energía que utilizan SAO* en el país. Este programa se introdujo en 2006 con el objeto de promover la sustitución completa de los viejos refrigeradores domésticos y equipos de aire acondicionado que consumen mucha energía. El programa ha contado con el apoyo activo de la dependencia nacional del ozono que se asegura de que las SAO no deseadas se recuperen como es debido, en consonancia con las mejores prácticas de refrigeración. En la actualidad, más de 2.757 millones de refrigeradores y 276.000 equipos de aire acondicionado, de 20 a 60 años de uso como promedio, han sido puestos fuera de servicio y sustituidos con unidades que aprovechan mejor la energía a un costo de más de 700 millones de dólares de los EE.UU. para el Gobierno de Cuba, que ha financiado el programa completo de acopio, sustitución y desactivación. El objetivo del programa es, a la larga, sustituir los 3 millones de

refrigeradores domésticos y 300.000 equipos de aire acondicionado estimados en el inventario del país. En el anexo I del presente documento se adjunta una propuesta de proyecto detallada.

Descripción del proyecto

5. Este proyecto piloto se ocupará al principio de eliminar 60,4 toneladas métricas (tm) de CFC-12 (o sea 15,1 tm anuales durante cuatro años) que ya han sido acopiadas mediante el Programa Nacional de sustitución y están listas para su destrucción. Además, también se ocupará de otros componentes previstos en el plan nacional de eliminación (PNE) para promover resueltamente la recuperación de SAO en Cuba y asegurarse de que el sistema de acopia se amplíe también a esta red. Se espera poder destruir, como cifra inicial, un total de 133 tm después de terminado el proyecto.

6. Como se señaló en la propuesta presentada originalmente, el proyecto tendrá como objetivo demostrar la viabilidad y las ventajas y desventajas respectivas de dos diferentes tecnologías de destrucción (ambas japonesas): una que utiliza un horno de cemento rotativo como opción técnica para la destrucción y la otra basada en la descomposición por arco de plasma. Ninguna de estas tecnologías se ha puesto a prueba en la región. Los aspectos económicos y la sostenibilidad de la destrucción de SAO en Cuba se examinarán en el contexto del programa de sustitución de refrigeradores del país. Se prevé que el proyecto de demostración se ejecute durante cuatro años, tras lo cual el gobierno seguirá explotando ambas instalaciones y velará por que las corrientes de desechos acopiados fluyan directamente hacia estos procesos para su destrucción.

7. En lo que respecta al horno de cemento, el Gobierno seleccionó una planta que se pudo designar como centro de eliminación de las SAO. Esta planta cuenta con cuatro hornos rotativos, de los cuales se han propuesto dos que se adaptarán con este fin. Se espera lograr de esta manera una capacidad de destrucción combinada de 10,3 tm anuales. En la propuesta explicaron también las razones por las cuales los hornos de cemento rotativos son una buena opción técnica para la destrucción de SAO.

8. Se espera lograr con ambas tecnologías una destrucción de SAO en consonancia con la tasa de destrucción de 99,99% de eficiencia de destrucción y eliminación (EDE). Los resultados de los ensayos con el dispositivo de arco de plasma demostraron una tasa de descomposición del 99,99% sin que se detectaran emisiones de dioxinas.

Cálculo de las SAO a eliminar

9. Las fuentes de SAO que se destruirán provendrán fundamentalmente del actual programa nacional de rendimiento energético y del programa de sustitución de refrigeradores, así como del programa nacional de recuperación de refrigerantes apoyado por el PNE. Gracias al programa nacional de sustitución se han retirado y desmantelado cerca de 2,6 millones de refrigeradores y equipos de aire acondicionado, lo que permitió acopiar 48,3 tm de CFC y 84,8 tm de HCFC, para un total de desechos de SAO disponible de 133 tm. Estos desechos se encuentran actualmente almacenados en un almacén central de la Habana. En Cuba se ha establecido también una eficaz red de recuperación y reciclado en el marco del PNE, y el país espera utilizarla para la posible recuperación de otras 199 tm de desechos de SAO. En el proyecto se prevé la destrucción de 15,1 tm anuales durante cuatro años.

Gestión institucional y financiera del proyecto

10. El régimen nacional de Cuba, que está bajo el control centralizado del gobierno, crea una situación excepcional respecto de la gestión de este proyecto de destrucción de SAO. La recuperación, el acopio y la destrucción de SAO en Cuba se llevará a cabo en dos etapas principales, en las que participarán tres entidades fundamentales que son organizaciones centrales con la responsabilidad total de ejecutarlas. A continuación se resumen las funciones de estas tres instituciones principales:

- a) El Ministerio de Ciencia, Tecnología y Medio Ambiente, por conducto de su Oficina Técnica del Ozono, está encargado de reglamentar, implementar, inspeccionar y controlar la recuperación, el acopio, el transporte, la destrucción y las emisiones de SAO;
- b) El Ministerio de la Construcción (MICONS), por conducto de su Grupo Empresarial del Cemento y la fábrica de cemento de Siguaney, tendrá la responsabilidad de destruir las SAO recuperadas en el país;
- c) El Ministerio de Comercio Interior, por medio de sus Empresas de Equipos y Servicios Industriales, está encargado de la totalidad del proceso de recuperación, acopio y transporte de los desechos de SAO que llegan a la instalación de destrucción.

11. En la propuesta se prevé que la financiación con cargo al Fondo Multilateral sufrague los costos de capital relacionados con la tecnología necesaria para la modernización con tecnología japonesa del horno de cemento, que será el centro de eliminación de SAO, y con la ejecución y funcionamiento del proyecto piloto durante 4 años. También se prevé que cubra ciertos gastos necesarios para el transporte de las SAO de desecho procedentes de los centros de acopio hasta el almacén central y luego al centro de eliminación definitiva, así como los gastos de supervisión del proyecto propiamente dicho. Gracias a la inversión inicial del Fondo Multilateral para instalar el horno de cemento se podrá contar con una instalación de eliminación que será administrada por el Gobierno de Cuba en estrecha vinculación con el programa nacional de sustitución de refrigeradores.

12. En lo que respecta a las demás fuentes de financiación necesarias para mantener el proceso en el futuro, en la etapa actual el proyecto piloto en Cuba no considerará ningún mecanismo basado en el mercado fuera de su propio apoyo nacional al programa, aunque estudiará otras posibles soluciones que se ajusten a su situación actual. El Gobierno de Cuba seguirá financiando el funcionamiento de los centros de recuperación y reciclado, así como otras actividades en el marco del programa de sustitución de refrigeradores que, en este caso, se puede calificar de cofinanciación de la inversión para este proyecto por parte de Cuba.

Vigilancia y verificación de la destrucción

13. El Gobierno de Cuba ha puesto en marcha un plan de vigilancia y verificación obligatorio, minucioso y estricto que ya se está llevando a cabo con el proceso de recuperación y acopio. Con ello se trata de evitar la duplicación y los errores, pero muy en particular de garantizar la trazabilidad y la cadena de custodia de los equipos recuperados, las SAO que contienen y su transporte hacia el almacén. Este sistema será el fundamento del sistema de vigilancia, que se seguirá reforzando y adaptando para mantener bajo vigilancia constante a las SAO desde el lugar de almacenamiento hasta su destrucción final, tanto en el caso de la destrucción mediante la tecnología del horno de cemento rotativo como mediante la tecnología que utiliza el arco de plasma.

Costo del proyecto

14. El costo total del proyecto se ha calculado en 792.763 dólares de los EE.UU. más gastos de apoyo del PNUD por la suma de 59.457 dólares de los EE.UU., como se solicitó originalmente y se indica en el cuadro que figura a continuación.

Cuadro 1: Costo del proyecto

Tareas	Actividad	No. de unidades	Precio por unidad en \$EUA	Costo
General				
Transporte local	Equipo especializado para el transporte local de SAO en Cuba (1000 talleres -> 169 centros municipales -> 80 centros de R&R -> almacenes centrales -> Eliminación final).	2	35.000	70.000
Gastos de funcionamiento del centro de eliminación	Administrador (3 años)	Si procede		Contribución del gobierno
	Adjunto (3 años)	Si procede		Contribución del gobierno
	Alquiler de locales	Si procede		Contribución del gobierno
	Equipo de oficina (incluidas las computadoras para el control)			10.000
	Gastos de funcionamiento (agua, electricidad)	Si procede		Contribución del gobierno
	Medios de identificación de los refrigerantes	4	5.000	20.000
	Equipo de reciclado	1	40.000	40.000
	Cilindros	1.000	80	80.000
Total parcial				220.000
Costos de capital – Tecnología de horno de cemento				
	Tablero de control automático para 2 hornos	1	70.000	70.000
	Equipo, que incluye medidores (alta presión, baja presión), válvulas de paso, registros, boquillas (para alta y baja presión), filtros de aire y aceite, transmisor electrónico de la velocidad de conducción, analizador electrónico de gases de combustión	1	122.000	122.000
	Componentes eléctricos, lo que incluye cables, interruptores, mangueras, soportes, cajas de los interruptores, tablero de control, etc.	1	5.000	5.000
	Componentes hidráulicos, que incluyen elementos calefactores, cilindros de gas, válvulas de seguridad, boquillas, medidores, soportes, tuberías de acero inoxidable, balanza electrónica, identificador de gas portátil, etc.	1	35.000	35.000
	Costo de la fuerza de trabajo para el diseño y la construcción de los sitios	Si procede		Contribución del gobierno

Total parcial				232.000
Costos de capital – Tecnología de arco de plasma				
	Aparato de destrucción de SAO por arco de plasma	1	115.700	115.700
	Mantenimiento de las partes durante 4 años de funcionamiento (=4.800 horas)	4	23.500	94.000
	Puesta en marcha y capacitación (un ingeniero del Japón)	1	13.400	13.400
	Transformador con estabilizador	1	26.300	26.300
	Dispositivo de protección contra apagones (reserva de pilas de suministro de energía no interrumpible)	1	29.000	29.000
Equipo de recuperación	Eco-Saver Tetra, 100V-120V con Std Acc	1	3.790	3.790
	Eco-Saver R350 100V-120V con Std Acc	1	8.200	8.200
	Válvula de aguja	1	166	166
	Colector con válvula	1	133	133
	Colector sin válvula	1	74	74
Total parcial				290.763
Asistencia y divulgación				
Asistencia técnica	Transferencia de tecnología (Consultor internacional)	1 visita anual, 2 años	30.000	30.000
Divulgación y supervisión	Reuniones de trabajo para el intercambio de información con otros países de la región y Sistema para controlar/vigilar el uso y los movimientos de cilindros vacíos/lLENOS, identificadores, cromatografía de gases	2	10.000	20.000
Total parcial				50.000
Total general				792.763

OBSERVACIONES Y RECOMENDACIÓN DE LA SECRETARÍA

OBSERVACIONES

15. La Secretaría formuló al PNUD algunos señalamientos y observaciones acerca de la propuesta en su forma revisada aplicando los criterios establecidos en la decisión 58/19.

16. La Secretaría pidió al PNUD aclaraciones sobre la cantidad de desechos de SAO que se destruiría. Pese a que en el proyecto se indica que la meta es destruir 15,1 tm anuales, también se menciona que hay 133 tm ya acopiadas. En su respuesta, el PNUD confirmó que en la propuesta de proyecto se indica que se destruirán 60,4 tm de SAO durante los cuatro años que durará el proyecto. También se menciona que el proyecto aprovechará actividades realizadas con anterioridad para crear la infraestructura necesaria que permita al país destruir las existencias acopiadas de desechos de SAO restantes y las futuras. Por ende, el Gobierno de Cuba confirma que, a la larga, se destruirán 133 tm de SAO. Los primeros cuatro años contarían con la cofinanciación del Fondo Multilateral y las operaciones

futuras correrán por cuenta del Gobierno de Cuba. El PNUD aclaró también, a propósito de los HCFC que se habían acopiado, que el país los reutilizaría en todo lo posible y solo destruiría lo que estuviese totalmente contaminado.

17. Al examinar la solicitud de preparación del proyecto que establecía los fundamentos para la presentación del presente proyecto, la Secretaría observó que la aprobación de los fondos para la preparación se basó en la idea de que en el país se adaptara la tecnología de hornos de cemento y, por consiguiente, pidió que se justificara la inclusión de la tecnología de destrucción por arco de plasma. La Secretaría observó además que este proceso ya había quedado demostrado en otro proyecto del PNUD, aunque en otro país, y que esa tecnología ya se podía adquirir en la red comercial. El PNUD señaló el interés del Gobierno de Cuba en examinar ambas opciones y determinar cómo se podía lograr que funcionasen simultáneamente. No obstante, reconoció que los fondos para la preparación del proyecto se habían fundamentado en la tecnología del horno de cemento y convino en ajustar la propuesta para que coincidiese con la expectativa inicial del proyecto.

18. La Secretaría expresó también que le preocupaba la falta de un modelo empresarial oficial que asegurase la sostenibilidad del proyecto cuando cesara la financiación. El PNUD aclaró que el concepto de modelo empresarial era algo diferente en el contexto cubano. La fábrica de cemento es propiedad del gobierno y está bajo su administración, mientras que los gastos de funcionamiento son y seguirán siendo sufragados por el gobierno. El Gobierno proporcionará los servicios de destrucción, razón por la cual será su responsabilidad sufragar los gastos de funcionamiento de esos servicios y el Gobierno remunerará a las empresas que participen en el proceso. Dado que el país está plenamente comprometido con la terminación no solo de la parte del proyecto relativa al aprovechamiento energético sino también de la destrucción de las SAO, cabe esperar que este sistema, con la asistencia del Fondo Multilateral para gastos de capital, se pueda utilizar también para demostrar un proceso de destrucción total en otros pequeños Estados insulares en desarrollo, quizás con inversión privada, si se considera lucrativo.

19. En el contexto de las conversaciones con el Comité Ejecutivo, la Secretaría recordó al PNUD la importancia de examinar la posibilidad de utilizar otras fuentes de financiación que pudieran contribuir a la sostenibilidad del proyecto. Mencionó que en el documento se plantea que los mecanismos basados en el mercado no eran a la sazón una opción debido al prolongado proceso que entrañaría y pidió al PNUD que aclarara cómo encajaba esto en sus actuales programas encaminados a procurar otras fuentes de financiación para los créditos de carbono de los que la destrucción de SAO se podría beneficiar. El PNUD aclaró que en esos momentos estaba trabajando activamente para detectar otras fuentes de financiación para los créditos de carbono, y que esta estrategia se estaba aplicando también en otros proyectos de demostración sobre gestión de los desechos de SAO. Sin embargo, en el contexto de la propuesta en curso relacionada con Cuba, no se considera una opción viable a corto plazo. Cuba se encontraba en las etapas iniciales de estudio de las posibilidades de acceder a los mercados de carbono. El Gobierno estaba dispuesto a seguir estudiando esta opción en el futuro, pero no deseaba que el proyecto dependiese de factores que estaban totalmente fuera de su control. La opción de que los mercados de carbono pudieran ser una fuente potencial de cofinanciación de futuras operaciones de gestión de los desechos de SAO en Cuba se seguiría estudiando tan pronto se hubiese completado el proyecto de demostración.

20. En lo que respecta a la cuestión de la verificación de las cantidades de SAO que se van a destruir, el PNUD informó a la Secretaría de que la empresa de cemento asumirá la plena responsabilidad por la destrucción de las SAO en el horno de cemento. Se propone que cada mes la empresa presente un informe oficial al Ministerio de Ciencia, Tecnología y Medio Ambiente y todos los años a la Oficina Nacional de Estadística. El Centro de Inspección y Control Ambiental tendrá la responsabilidad de llevar a cabo auditorías periódicas para asegurarse de que las cantidades de SAO sean eliminadas efectivamente de manera ambientalmente racional. La dependencia nacional del ozono también llevará a cabo inspecciones periódicas en la instalación de destrucción de la fábrica de cemento. Los cambios propuestos en la fábrica de cemento estarán bajo la supervisión técnica de las entidades asociadas del

Gobierno del Japón, y se han concebido de manera que se cumplan las normas de destrucción internacionales (99,99% EDE).

21. La Secretaría preguntó también acerca de la duración propuesta del proyecto presentado, que era de cuatro años, y la expectativa de que se completase en uno o dos años de manera que los resultados fuesen útiles para otros países. El PNUD mencionó que el primer año sería un período de inversión inicial y que la instalación y las pruebas podrán comenzar poco después. La constante verificación y supervisión de los procesos son importantes para optimizar la eficacia del sistema al tiempo que se reduce al mínimo la posibilidad de que se dañe el equipo, razón por la cual habría que dedicar algún tiempo también para destruir una cantidad razonable de desechos de SAO. Pese a que cabría la posibilidad de dar a conocer a otros países de la región los resultados iniciales al cabo de los dos primeros años, es importante que el sistema siga funcionando para introducir los ajustes y precisiones necesarios que contribuyan a garantizar el funcionamiento prolongado del sistema de manera rentable y sin riesgos. Esto se aplica no solo a la destrucción de SAO, sino que tiene igual importancia para la logística relacionada con el sistema de gestión de SAO (transporte, almacenamiento, etc.) en Cuba. No obstante, considerando las preocupaciones expresadas por la Secretaría, el PNUD estuvo de acuerdo en ajustar el período de ejecución a tres años.

22. La Secretaría analizó también con el PNUD la financiación solicitada para el proyecto y señaló que no se podían recomendar los gastos correspondientes al equipo de plasma. La Secretaría pidió también aclaración acerca de los costos relacionados con una máquina de recuperación porque presuntamente las sustancias ya se habían acopiado. El PNUD aclaró que este equipo no se necesitaba para recuperar SAO de equipos obsoletos sino más bien para trasvasar las SAO entre cilindros a fin de facilitar el transporte. La Secretaría pidió al PNUD que ajustara los costos de conformidad con este análisis. Dicho ajuste redujo el costo a 11,6 \$EUA/kg de SAO destruida a razón de 15,1 tm anuales durante tres años. Este costo se ajusta a la financiación máxima autorizada de 13,2 \$EUA/kg en la decisión 58/19, puesto que Cuba es un país que no tiene un bajo nivel de consumo. Se convino en establecer el costo final del proyecto en 525.200 \$EUA más gastos de apoyo, como se resume a continuación:

Cuadro 2: Costos convenidos del proyecto

Tareas	Actividad	No. de unidades	Precio por unidad en \$EUA	Costo	Finalidad
General					
Transporte local	Equipo especializado para el transporte local de desechos de SAO en Cuba (1000 talleres -> 169 centros municipales -> 80 centros de R&R -> almacenes centrales -> Eliminación final). Incluida la adaptación de vehículos.			70.000	Transporte
Gastos de funcionamiento del centro de eliminación	Administrador (3 años)	Si procede		Contribución del gobierno	
	Adjunto (3 años)	Si procede		Contribución del gobierno	
	Alquiler de locales	Si procede		Contribución del gobierno	

	Equipo de oficina (incluidas las computadoras para la supervisión)			10.000	Supervisión
	Gastos de funcionamiento (agua, electricidad)	Si procede		Contribución del gobierno	
	Equipos de recuperación industrial (trasvase de desechos de SAO entre cilindros), equipo auxiliar, herramientas correspondientes, detectores de SAO, materiales, etc.	6	10,000	60.000	Transporte y almacenamiento
	Cilindros de almacenamiento provisional en los 1000 talleres.	1,000	80	80.000	Almacenamiento
Total parcial				220.000	
Costos de capital – Tecnología de horno de cemento					
	Tablero de control automático para 2 hornos	1	70.000	70.000	Dstrucción
	Equipo, que incluye medidores (alta presión, baja presión), válvulas de paso, registros, boquillas (para alta y baja presión), filtros de aire y aceite, transmisor electrónico de la velocidad de conducción, analizador electrónico de gases de combustión	1	122.000	122.000	Dstrucción
	Componentes eléctricos, lo que incluye cables, interruptores, mangueras, soportes, cajas de los interruptores, tablero de control, etc.	1	5.000	5.000	Dstrucción
	Componentes hidráulicos, que incluyen elementos calefactores, cilindros de gas, válvulas de seguridad, tomas, medidores, soportes, tuberías de acero inoxidable, balanza electrónica, identificador de gas portátil, etc.	1	35.000	35.000	Dstrucción
	Costo de la fuerza de trabajo para el diseño y la construcción de sitios	Si procede		Contribución del gobierno	
	10 % para imprevistos		23.200	23.200	
Total parcial				255.200	

Asistencia y divulgación					
Asistencia técnica	Transferencia de tecnología, capacitación (Consultor internacional)			30.000	Destrucción
Divulgación y vigilancia	Reuniones de trabajo para el intercambio de información con otros países de la región y Sistema para controlar/vigilar el uso y los movimientos de cilindros vacíos/llenos, identificadores, cromatografía de gases			20.000	Divulgación y supervisión
Total parcial				50.000	
Total general				525.200	

RECOMENDACIÓN

23. El Comité Ejecutivo tal vez desee considerar la posibilidad de:

- a) Tomar nota con reconocimiento de la solicitud del Gobierno de Cuba de un proyecto piloto de gestión y eliminación de los desechos de SAO para destruir un total de 45,3 toneladas métricas de desechos de SAO;
- b) Aprobar la ejecución de un proyecto piloto para la gestión y destrucción de los desechos de SAO en Cuba por la suma de 525.200 \$EUA más los gastos de apoyo para el PNUD por la suma de 39.390 \$EUA, sobreentendiéndose que no se pondrán más fondos a disposición de Cuba ni de ningún otro proyecto de eliminación de SAO en el futuro.



Project Document

Government of Cuba

United Nations Development Programme

Funded by the Multilateral Fund (MLF) for the Implementation of the Montreal Protocol

Pilot Demonstration Project on ODS-Waste Management and Disposal

31 October 2010

COUNTRY:	Cuba	IMPLEMENTING AGENCY: UNDP
PROJECT TITLE:	Pilot Demonstration Project on ODS-Waste Management and Disposal	
PROJECT IN CURRENT BUSINESS PLAN:	Yes	
SECTOR:	ODS-Waste	
Sub-Sector:	Refrigeration Servicing Sector	
PROJECT IMPACT (ODP targeted):	15.1 Metric Tons/year of CFC-12	
PROJECT DURATION:	36 months	
PROJECT COSTS:	US\$ 964,590	
LOCAL OWNERSHIP:	100 %	
EXPORT COMPONENT:	0 %	
REQUESTED MLF GRANT:	US\$ 525,200	
IMPLEMENTING AGENCY SUPPORT COST:	US\$ 39,390 (7.5 %)	
TOTAL COST OF PROJECT TO MLF:	US\$ 564,590	
COST-EFFECTIVENESS:	US\$ 3.95/kg ODS (metric) based on complete destruction of recovered ODS Waste in Cuba. Not all will be destroyed during the 3 year demonstration project.	
PROJECT MONITORING MILESTONES:	Included	
NATIONAL COORDINATING AGENCY:	Technical Ozone Office: Ministry of Science, Technology and the Environment	

Brief Description.

The Technical Ozone Office of the Ministry of Science, technology and the Environment in collaboration with UNDP Cuba has developed an overarching strategy to provide ozone benefits through the Integrated Plan for ODS Reductions for the Refrigeration Sector as shown in Figure 1. This integrated plan brings about the convergence of 3 synergistic interventions: (i) the promotion of energy efficient refrigerators (Cuba), (ii) the project for the recovery and destruction of ODS (Cuba/MLF), and, the chiller replacement project (Cuba/Environment Canada/MLF); The ultimate objective of this plan is to bring economic, social and environmental benefits to the people in Cuba through the scaling up towards energy efficient appliances with low global warming potential (GWP) and zero ozone depleting potential (ODP).

This project seeks to demonstrate the safe and efficient disposal of ODS refrigerants recovered from early retired or end of life (EOL) refrigerators/freezers, air-conditioners and from the servicing sectors using technology developed by Japan for cement kilns and not previously tested in the region. In order to remain within the reasonable budget, the foams recovered from the project will not be considered for destruction under the current project and have been stored for subsequent destruction. The project will continue to destroy ODS Waste once it has been completed.

Although the country is interested in pursuing these options, at present it would in practical terms seem difficult to generate a project for the voluntary market to monetize the ODS destroyed as carbon credit. However, the project will, in keeping an eye to the future, explore this as well as other potential co-financing options.

Lessons learned from this pilot will be shared with other SIDS, as well as Central American countries, and a business model could be developed based on the Cuban experience.

1. INTRODUCTION AND BACKGROUND.

The Government of Cuba is requesting funding for a pilot project to evaluate and demonstrate the safe disposal and destruction of ODS. Cuba has already advanced significantly as regards other aspects included in Decision 58/19, namely recollection, demanufacturing, transport and storage and this final component of management of collected stocks, transport (logistics) and destruction would ensure that the full circle is completed. The project complies with the criteria established by Decision 58/19 including focus on specific aspects not addressed by other pilot projects.

This project will be the first of its kind in the Caribbean region, and it will generate valuable information about possible models to establish a long-term self-sustaining system to collect ODS from the banks and destroy them. Furthermore, this information will also be helpful to other countries interested to undertake similar approaches to manage their ODS banks. As there is no ODS destruction technology or equipment in the neighboring Small Island developing States (SIDS), there is great potential to collect, recover and destroy ODS in banks and in old inventory stocks which further justifies the investment.

The proposal for Cuba contains the following unique and innovative features:

- Out of the 33 ODS Destruction pilots included in the three agencies and Japan business plans, this is the only one addressing all the aspects of a complete ODS waste management system in a SIDS. Although one of the demonstration projects already approved will explore regional and sub-regional transportation of ODS among countries in Asia (possibly including some islands), this is not the case in Cuba where local destruction is considered part of the strategy. As well, none of the demonstration projects approved deal with the logistical characteristics of SIDS.
- If destroying ODS in Cuba is proven to be viable, any lessons learned regarding regional transport could likely be adapted to and used by other islands and Central American countries. The project will generate important lessons regarding economic, environmental, logistical, technical, etc. aspects related to ODS destruction (recollection, transport, storage and final disposal). Similar countries in the Caribbean and CA will be able to learn from this experience and will be able to take informed decisions about their future ODS disposal strategy. It is important to remember that although there are two countries with operational ODS destruction capacity in the region, none of them is at present likely to receive ODS from other countries due to their national waste management policies. For example, Cuba previously explored the possibility of exporting ODS for destruction to other countries however, many barriers (economic, legal, Basel and Rotterdam conventions stipulations, etc.) make it difficult for Cuba to export ODS for destruction. Given the large quantity of ODS that Cuba has already recollected as well as the perspectives for the future collection in light of ongoing efforts, it is considered of the utmost importance to have a national based solution for ODS destruction.
- The demonstration project will build on a remarkable 4 year energy efficiency strategy that is currently in it's last stages, and through which 2.6 million CFC based domestic

refrigerators and air conditioning units have been collected and dismantled, and from which over 48.3 tones of CFC have been collected for destruction. It will in particular help to reinforce the necessary conditions to determine the appropriate logistics for transport, storage and destruction of ODS in Cuba and will explore different options in order to ensure the long-term sustainability of the process.

- With the exception of the destruction technology, and the logistics, storage and transport to ensure the environmentally sound destruction of the collected substances, Cuba has already developed most of the individual components that are needed for a comprehensive ODS destruction system (recollection, transport, storage and destruction). There is a wealth of accumulated data that would take years to collect in a pilot where no previous collection efforts had been undertaken. The challenge and objective of the requested assistance is to set up and fine tune the logistics required to bring all the individual pieces together and make them into a comprehensive and sustainable system coordinated by the central government.
- The purpose of the project is to set up and firmly establish the necessary logistics framework to ensure the effective destruction of ODS (transport, storage, disposal) and demonstrate how it will work in the context of a Small Island Developing State. In particular the project aims to demonstrate the feasibility and respective advantages/disadvantages of destruction technology developed and fine tuned by Japan using rotary cement kilns, which has never previously been tested in the region. The economics and sustainability of ODS destruction in Cuba will be explored in the context of the country's replacement programme, as mentioned above. In 2006 and 2010 a technical delegation from the government of Cuba was invited by the government of Japan to attend demonstrations of the ODS technologies. Subsequent to the demonstrations it was considered that the technologies could perfectly fit the needs of Cuba and countries with comparable characteristics. Given this, Cuba carried out a feasibility study to evaluate a possible site for the cement kiln technology and it was determined that the kiln of the "Fabrica de Siguaney" (Siguaney factory) in the Sancti Spiritus Province of central Cuba was an ideal candidate.
- The country has already invested heavily in this strategy and is willing to continue to support this in the future. With regards to alternative/complementary financial sources to maintain the ODS destruction operations in the future, although the interest exists on the side of Cuba - and even though the Caribbean is underrepresented in the global carbon market - unlike other demonstration projects, the pilot project in Cuba will not consider, at this stage any market based mechanisms. Given in particular Cuba's geopolitical situation it would be difficult to commit to any strategy that will depend on market based mechanisms. The demonstration will focus on alternative solutions to the market based solutions tested in other countries. However it must be pointed out that this is due to the length of the process, and not to a lack of interest. This option would potentially be further explored in the future.

• 2. OVERARCHING STRATEGY AND PROJECT OBJECTIVES

With the support of the Multilateral Fund (MLF) the implementation of a National Phase-Out Plan is being completed in Cuba through which the CFC phase-out has been fully addressed. In addition, as the phase-out of HCFCs - which have Ozone Depleting Potentials (ODPs) of only 5 to 10% of those of CFCs - is now being supported as well by the MLF, the formulation of an HCFC Phase out Management Plan (HPMP) for Cuba is being pursued.

In this context, and in order to maximize the benefits of a Cuban *National Total Substitution Programme for High-Energy Consuming, ODS Based Refrigerators and Air Conditioners*, the Technical Ozone Office of the Ministry of Science, Technology and the Environment, in collaboration with UNDP Cuba has developed an overarching strategy to provide ozone benefits through an Integrated Plan for ODS Reductions for the Refrigeration Sector as shown in Figure 1.

This integrated plan brings about the convergence of 3 synergistic interventions:

- (i) Promotion of energy efficient appliances through substitution (Cuba);
- (ii) Project for the recovery and destruction of ODS (Cuba/MLF); and, longer term,
- (iii) Chillers replacement project (Cuba/Environment Canada/MLF).

The ultimate objective of this plan is to bring economic, social and environmental benefits to the people in Cuba through technological scaling up towards energy efficient appliances with low global warming potential (GWP) and zero ozone depleting potential (ODP).

Cuba has regulations in place that prohibit the deliberate emission of ODS into the atmosphere (both CFCs and HCFCs) and, as a result, large quantities of ODS have been recollected, amongst others, through the ongoing Substitution Programme for Domestic Refrigeration and Air-conditioning. In addition, ODS from the Chillers replacement programme and the Commercial retrofit programme are also in the process of being recollected.

It is important to note that trained technicians in Cuba are required by law to avoid ODS emissions, to recover ODS from older equipment during maintenance, and to hand over the recuperated refrigerant to the workshops under the supervision of the MINCIN (Interior Commerce Ministry). There is still a large bank of ODS that will benefit from this project, and the government of Cuba is actively promoting their recovery for their eventual destruction.

The ODS waste demonstration project will focus on all aspects described in decision 59/19 (transport, storage and destruction). The project will address ODS waste that has already been recollected and it will also firmly establish a system that will allow Cuba to deal with the destruction of ODS waste to be recollected in the future.

This proposal covers the initial start up costs for the comprehensive ODS Waste Management System in Cuba, and will allow Cuba to destroy the complete current inventory of 133 tons of ODS waste. This would give a CE of approximately 3.95 US\$ / kg ODS destroyed.

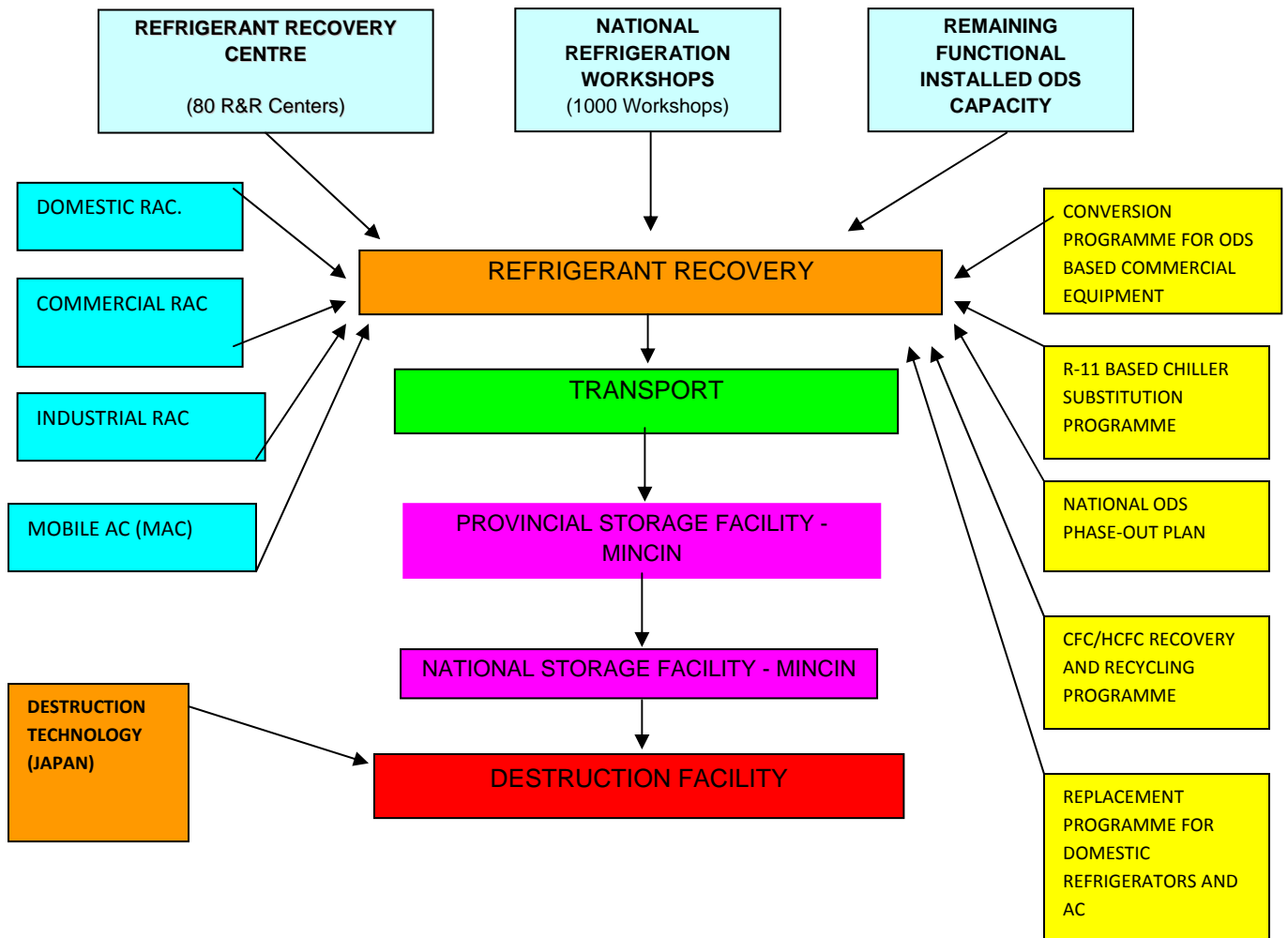

Figure 1 - Integrated Plan for ODS Reductions for the Refrigeration Sector

3. JUSTIFICATION FOR THE ODS-DISPOSAL PILOT PROJECT

The Executive Committee, at its 58th Meeting approved a set of interim guidelines for the funding of demonstration projects for the disposal of ODS in accordance with paragraph 2 of decision XX/7 of the Meeting of the Parties. The following information is provided to comply with all of the requirements as set out by the above mentioned Decision 58/19:

3.1. Updated and more detailed information on all issues that were required for obtaining project preparation funding

i. An indication of the category or categories of activities for the disposal of ODS (collection, transport, storage, destruction), which will be included in the project proposal

In 2006, Cuba introduced the Energy Revolution Year where one important component was to promote the complete substitution of old energy inefficient domestic refrigerators and air-conditioning units. The programme has been actively supported by the National Ozone Unit to ensure that ODS have been properly recovered, following best refrigeration practices. At present, over 2.757 million refrigerators and 276,000 air-conditioning units, on average 20 to 60 years old, have been de-manufactured and replaced with energy efficient units at a cost of over 700 million US dollars to the government of Cuba which has funded the complete recollection, substitution and de-manufacturing programme. The programme aims to ultimately replace the estimated 3 million domestic refrigerators and 300,000 air-conditioning units inventoried in the country.

Under the National CFC Phase Out Plan more than 80 Recovery and Recycling centers have been established and they are playing an invaluable role in the recovery of refrigerants. Although this strategy has born its fruit, the most pressing challenge in Cuba is now related to the setting up of the logistics for a storage, transport and destruction system for the portion of recovered ODS that are so contaminated as to make them unfit for reuse.

The present project will build from the experience gained through the development and implementation of this and previous related programmes and projects to propose a sustainable long term collection, transportation, storage and destruction scheme that could expand to ODS extraction from other kind of banks (i.e. commercial refrigeration and chillers), and eventually HCFC.

ii. An indication of whether disposal programmes for chemicals related to other multilateral environmental agreements are presently ongoing in the country or planned for the near future, and whether synergies would be possible

There are currently no other ongoing chemical disposal programmes in Cuba

iii. An estimate of the amount of each ODS that is meant to be handled within the project

Cuba has under the National Substitution Programme recovered a total of 133.1 tons of ODS (48.3 tons of CFC and 84.8 tons of HCFC) and in addition, other components under the NPP strongly promote the recovery of ODS in Cuba (additional domestic refrigerators, air-conditioning units, Commercial retrofit programme and Chillers replacement programme). As the recovered ODS comes from more than 3 million pieces of equipment, and as only small quantities have been recovered from each unit, the risk of contamination, mix of different refrigerants, etc. was very high. Although some quantities of HCFCs have been recycled, the large bulk of it, corresponding to quantities mentioned herein are not fit for recycling/reclaim.

The government has indicated its intention to destroy 133 tons of recovered and contaminated ODS, and it expects to recover additional ODS waste in coming years. The first four years of this effort would be co-financed by the MLF.

An initial structure for recovery and recycling is set up in Cuba, and the country expects to build this up to recover additional ODS in the coming years. Although this is offered for information only, a total of up to 299 tons of ODS (including what has already been recovered) could potentially be recovered under the NPP, the Chillers substitution project, and the continuation of the Substitution Programme for Domestic Refrigerators and Air-Conditioning Units.

Description	Quantity (T)	R-12	R-11	R-22
National Substitution Programme for Domestic Refrigerators and Air-Conditioning Units	133,1	48,3	-	84,8

iv. The basis for the estimate of the amount of ODS; this estimate should be based on known existing stocks already collected, or collection efforts already at a very advanced and well-documented stage of being set up

As mentioned in iii) above, more than 133 tons of ODS have already been recovered and are currently stored in Cuba, as can be seen from the picture below which was taken in the Central Storage Facility situated in Havana. This shows 1 ton cylinders containing contaminated refrigerant waiting to be processed for destruction.



v. For collection activities, information regarding existing or near-future, credible collection efforts and programmes that are at an advanced stage of being set up and to which activities under this project would relate.

The substitution of domestic refrigerators and air-conditioning units programme is under full implementation and has been so for several years. As previously pointed out, the Government of Cuba has fully and exclusively funded this and no other donors have been involved in the programme. The Commercial Retrofit programmes under the National Plan, as well as the Chillers replacement projects also actively promote the additional recovery of CFCs.

The replacement programme has benefited the entire population with the replacement of older equipment to new, non-ODS based and energy efficient one. The citizens only pay the real bulk-purchase costs of the units. The transport costs are covered by the government and, multi-year, interest-free payment facilities are provided to the population as an incentive. The refrigerators are picked up at the users domicile, and transported to a specialized center where they are unloaded and where a triage takes place to determine the likely type of refrigerant they contain. The refrigerant is then extracted and stored first in 50 lbs cylinders and then transferred into 1 ton cylinders and great care is taken to avoid accidental releases. The refrigerator carcasses are then transported to a recycling facility where they are dismantled and used as raw material.

The national programme for substitution of domestic refrigerators expects to replace an additional 200,000 domestic refrigerators. The commercial retrofit programme under the NPP is also contributing to recover additional ODS in Cuba. It is important to note that the government of Cuba established all the R&R centers in Cuba and covers the cost of their operation. In complement to what was elaborated above, ODS refrigerants are also recovered and recycled from the over 1,000 workshops disseminated throughout the country servicing companies, ministries, and the different sub-sectors including for example commercial, industrial and MAC.

The activities under the NPP (such as training of technicians, etc.) have been complementary to the programme. 170 Recovery machines were procured under the NPP, and they are currently located in the maintenance workshops in Cuba.

In particular under the Chillers substitution project 9 chillers of between 150 and 250 TR have been replaced with energy efficient and ODS free equipment and this will be extended to an additional 32 chillers in other institutions and areas of the country. The commercial Retrofit programme includes conversion of over 800 equipment units of different sizes and will provide the opportunity to recover more ODS.

vi. For activities that focus at least partially on CTC or halon, an explanation of how this project might have an important demonstration value

This project will focus exclusively on the destruction of contaminated CFCs and HCFCs and no CTC or halon will be involved in this pilot project.

3.2. Detailed information on issues required for project submission

i. Updated information for issues mentioned under project preparation

See above.

ii. Detailed description of the foreseen management and financial set-up.

The recovery, collection and destruction of ODS in Cuba will take place in two main phases and will involve three main partners, in the form of central organizations which will be fully responsible for its implementation.

This will take place with the support of the MLF and the assistance of UNDP.

It is to be noted that, where possible, the HCFC-22 from the commercial and domestic air-conditioners will be recycled for re-use to diminish the needs for ODS-imports.

Overview

Cuba has developed an incredible setup for the recovery and recollection of ODS with more than 1000 workshops of which 169 acts as municipal centers. On top of that, 80 regional Recovery and Recycling Centers were established under the domestic refrigeration substitution programme. The R&R centers were established and equipped and served as centers to demanufacture domestic refrigerators and air con units. This included the recovery of ODS. All workshops are obliged by the government to recover ODS during maintenance operations, and the government of Cuba is considering introducing a system in the future that will further promote/incentivize the recovery of ODS for recycling or destruction.

The operation of the recollection programme in Cuba is fully funded by the government, and most of the recovered ODS Waste comes from the following programmes

- Domestic Refrigerator Substitution Programme (including energy in-efficient Air con units).
- Chillers Replacement Programme
- Commercial Retrofit Programme under the NPP

No funds are being requested for the operation of the recollection scheme in Cuba.

Transport

Transport is a real challenge in Cuba. Transport of ODS waste has so far been done in an ad hoc manner and no structured approach has been taken. A clear limitation in Cuba is the lack of dedicated vehicles for transport of ODS waste, and there is also a lack of cylinders for transport of recovered ODS at the workshop level to municipal centers.

This proposal includes a component that will create a real structure for transport of recovered ODS waste at all levels in Cuba. This includes the procurement of specialized transport units plus the cost of adapting them to transport of ODS between the different actors in Cuba (1000

workshops, 169 municipal centers, 80 R&R centers, regional and central storage facilities, and final disposal at the cement factory. This would include recovery equipment, tools, and materials, ODS identifiers, ancillary equipment, etc. to transfer ODS from smaller to larger cylinders at the transport units.

The government of Cuba would cover the cost of all personnel involved in transport of ODS waste in the country.

Storage

Cuba has regional and central storage facilities that were created under the Domestic Refrigeration substitution programme.

The current system has its limitations and would need some improvements in order to be a fully operational system that would complement the general ODS Waste Management System in Cuba. The government of Cuba is requesting funds to cover the costs of procuring Recovery equipment and associated tools/ODS identifiers/materials/storage cylinders/ancillary equipment that would allow transfer of ODS waste from smaller to larger cylinders as well as temporary storage in the regional and central storage centers. The proposal also includes the procurement of 1000 cylinders that would allow each of the workshops to store temporarily recovered ODS waste until it is transported to the storage centers.

The proposal includes the procurement of 6 powerful recovery machines that can be placed in the specialized transport units (2) and in regional and central storage centers (4). It would be important to note that the recovery machines would need to have a high capacity in order to be able to transfer ODS waste between cylinders of different sizes in Cuba taking into consideration the hot temperatures in the country.

The government of Cuba covers all the operational costs of the facilities.

Final Disposal

The government of Cuba suggested initially pursuing a two-tier strategy with destruction of ODS waste in cement kilns and through the mobile plasma arc technology. Cuba has accepted the recommendation of the MLF Secretariat and will only request funding for the reconversion of the cement kilns at the cement factory.

The government of Cuba would like to request funding to cover the initial start up investment costs to adapt cement kilns to be able to destroy ODS waste. In annex 3 you will find the plans for the cement kiln reconversion and the associated costs have been calculated by the government of Cuba based on the recommendation from the Government of Japan. International experts would be needed to provide technical assistance for technology transfer and training of national experts.

The proposal also include the monitoring of emissions coming from the ODS Waste destruction. This is an important part of a MLF funded project.

The government of Cuba would cover all construction costs (labor) as well as labor costs related to assembling the ODS destruction system at the cement factory. The government of Cuba would cover all operating costs of the system.

10 % contingency has been added to investment costs.

Project Monitoring

A national team of experts will be set up to monitor project implementation and progress. This includes the monitoring of transport, storage and final disposal of ODS in Cuba in order to make the system more effective among all the stakeholders.

The national labor cost of the project-monitoring unit will be covered by the government of Cuba.

Dissemination of results nationally and internationally

Lessons learned will be documented and shared nationally as well as internationally. The project will generate valuable information about how to develop a full system of ODS destruction with a well placed collection, transport, storage and destruction system in place. This would allow other interested countries in setting up a business model that would be based on the Cuban experience.

Responsibilities of participants

- The Ministry of Science Technology and the Environment (Ministerio de Ciencia Tecnología y Medio Ambiente – CITMA, for its acronym in Spanish), through its Technical Ozone Office, is in charge of regulating, establishing, inspecting and controlling the recovery, collection, transport, destruction and emissions of ODS;
- The Ministry of Construction (MICON) through its Cement Business Group and the Siguaney Cement plant, will have the responsibility for destruction of ODS recovered in the country;
- The Interior Commerce Ministry (Ministerio de Comercio Interior - MINCIN for its acronym in Spanish), through the Industrial Equipment and Services Enterprise (Empresa Industrial de Equipos y Servicios - EIESA) is in charge of the totality of the process of recovery, collection and ODS transport until the destruction facilities;

- The MINCIN, through the EIESA is in addition in charge of the destruction of ODS through the Plasma Arc technology in the plant that will be set up in the central “Reforma” warehouses;
- The enterprises and entities that have servicing units (workshops), recovery centres and maintenance brigades as well as banks of equipment have the responsibility to recover and store reusable and/or contaminated refrigerants and to hand them over to MINCIN for final collection and storage;
- The enterprises that possess banks of equipment containing ODS refrigerants have the obligation to avoid their emission and must, at the end of their useful life, use or hire a servicing unit for the recovery and eventual destruction of the refrigerant.

Recovery, collection and transport of ODS

- All refrigeration servicing workshops and maintenance brigades in the country, belonging to any of the organisms (OACE – Organismo de Administracion Central del Estado) are required to avoid the release to the atmosphere of refrigerant from equipment being serviced, repaired, substituted or dismantled and must recover this, store it in equipment loaned to them, and hand it over to the municipal MINCIN workshops, the EIESA or others as previously agreed with the MINCIN. The entities will have recovery and recycling equipment, as well as cylinders to store the ODS to be destroyed.
- The EIESA-MINCIN workshops as well as the municipal MINCIN approved workshops are responsible for adequate handling and storage of ODS received and will deliver in exchange for these a certificate attesting the quantities received. These entities will have recovery and recycling equipment, as well as cylinders to store the ODS to be destroyed.
- The authorized specialized recovery and recycling centers will have the responsibility of avoiding emissions of refrigerant from equipment being serviced or dismantled and must recover this and hand it over to the municipal MINCIN workshops, the EIESA or others as previously agreed with the MINCIN. These entities will have recovery and recycling equipment, as well as cylinders to store the ODS to be destroyed.
- The EIESA of the MINCIN is the enterprise responsible for the recovery, collection and transport of the ODS recovered from the municipal workshops to the central storage facility of the EIESA MINCIN and, from this to the destruction facility. The EIESA will have specialized trucks with recovery and recycling equipment as well as cylinders to store the ODS to be destroyed.
- CITMA-OTOZ will determine the annual national quota for consumption of refrigerant fluids based on the international commitments established under the Montreal Protocol.
- MINCIN is in charge of refrigerant fluids and of the distribution of the quota for Cuba as established by CITMA. MINCIN will establish the basis for their distribution, which will be based on the total recovered amounts by the different stakeholders.

Collection Centers

There are two collection systems working in parallel in Cuba, one for ODS recovered from the refrigerator replacement project, and one covering all other aspects of ODS recovery. The first system is structured around 80 regional collection centers, and the second collection system includes 1000 local level workshops. As there are 169 municipalities, one of the above mentioned 1,000 workshops acts as a municipal level center. The ODS recovered by the 1,000 workshops thus feeds into 169 municipal level workshops. This is complemented by central storage facilities, including the main one in Havana.

Under the refrigerator dismantling project, after stockpiling, the refrigerators are transported to one of the 80 regional dismantling and recovery centres. This decentralized system has the advantage of avoiding the transport of the old refrigerators with dead weight over a long distance to a central area in Havana.

Upon receipt, data for each appliance is recorded, verified and entered into a computer. The ODS from each refrigerator is recovered by the technician using special equipment according to best practices, labeled and stored in cylinders and refrigerators are then dismantled by taking out the compressors and stripping out the door and walls.

The foam insulation is segregated from the metal door and wall. Metal, plastic and wires are sorted and sold to scrap metal dealers. Although the volume of foam that is available in Cuba may make it viable for a vacuum system to be deployed in order to avoid ODS emissions during the dismantling process, this is not contemplated by the country at present. The insulation foam is currently being landfilled for subsequent destruction.

The centers will be managed by trained Managers, supported by technician(s) and assistant(s). The operational costs and salaries will be paid by the Government of Cuba.

The pick up would be scheduled to take place on a regular basis (for example once a month) by means of two specialized truck, each equipped with high volume recovery equipment, identifiers etc and that would in turn deliver this to the destruction facilities. These trucks would also be tasked with maintaining the destruction facilities properly stocked so as to avoid any interruptions in the supply of ODS for destruction.

Equipment needs for the continued recovery, collection and transport of ODS (most of it already provided under NPP).

- Local Workshops
- Storage tanks
Recovery equipment
Hoses and connectors

- Municipal Workshops and R&R Centers

Storage tanks

Recovery equipment

Hoses and connectors

- Central Storage facility

Storage tanks

Recovery equipment

Hoses and connectors

Specialized mobile units for recovery including hoses (2)

2 Specialized vehicles are needed to transport the recovered ODS between the different levels (Workshops, Municipal Centers, R&R Centers, Central Storage Facilities, and Final disposal facility).

Equipment needs for destruction of ODS with rotary kiln technology

Rotary cement kilns provide an excellent technical option for the destruction of ODS given specific characteristics such as:

- High flame temperatures which can reach 1800-2000 C° and 1400-1500 C° in the substances, virtually guaranteeing destruction of all organic matter;
- Long residence times, as a consequence of large oven size and volumes, which can reach 6 seconds in the oven per-se, and not considering the residence time in the thermal interchange towers. This allows for the oxidation of all gas-phase organic compounds;
- Highly alkaline environment within the clinker kiln, which guarantees that all acidic components such as hydrochloric and hydrofluoric acids and other sulfur compounds (SO₂ and SO₃) will be neutralized;
- No residues are generated in the form of either ashes or scoria. In small quantities, heavy metals are incorporated, in a stable form, into the structure of the clinker and do not affect its properties or final quality.

Given the high temperatures and long residence times, these kilns are ideal vehicles to destroy organic compounds of a high chemical stability such as CFCs and HCFCs. The destruction of Freon gases in rotary cement kilns solves one of the main problems associated with the destruction of these kinds of substances, namely the emission of acidic gases (HCL & HF) given that these react with the calcium salts present in the primary feedstock, and combine to form CaCl₂ and CaF₂, these are not emitted as gases, but rather come to form a part of the clinker while not affecting its intrinsic properties or quality.

On the other hand, chlorine contained in these gases constitutes the main problem given that it can, not only affect the quality of the cement, but also the kiln itself. An excess of this gas in the hot gas flux of the kiln will contribute to the unlimited thickening of the crust that adheres to the refractory coating and that can reduce significantly the interior of the kiln, affecting its productivity and as a result the whole country, in particular as regards white cement as there is

only one such facility in the country. This effect is significantly more marked in dry process kilns.

For the above-mentioned reasons the precise and continuous control of the dosage of CFCs and HCFCs being injected into the kiln is the single most important requirement in the destruction process of these gases.

Consultation with local experts has indicated that there are at least one cement plant in Cuba that can be set up as an ODS-Disposal Centre and used for the destruction of ODS waste. This facility, known as the Siguaney Cement Plant of the Grupo Empresarial del Cemento (Cement Business Group) is located in the town of Siguaney located in the province of Sancti Spiritus, approximately 300km to the South-East of Havana. This facility includes 4 rotary kilns (3 for grey process, one for white, each capable of producing 22 tons per hour) that are slated to produce for 2011 a total of 141,000 tons of grey cement and 56,000 tons of white cement under the humid type process.

It is proposed under this project to adapt 2 of the 4 kilns for destruction (one producing grey and one producing white cement). The combined clinker production capacity for 2011 of these two kilns is planned at 103,000 tons, which, considering a destruction potential of 0.1kg of CFC/ton of clinker represents a destruction capacity slightly under 10.3 tons of CFC per year (or a higher quantity of other types of ODS waste).

The required set up for the injection of ODS into the kilns includes:

Area for reception and storage of cylinders – requires the construction of a closed facility to store cylinders at ambient temperature and includes a scale for weighing as well as a system to transport them.

Dosage area – requires the construction of a closed facility where the conditions for the positioning of the cylinders from which the gas will be injected into the kiln will be created. This includes:

- Tanks to place the cylinders in a 30^o C bath to facilitate the extraction of the gas. For 100 kg cylinders a system of irrigating collars to increase the height of the bath will be required;
- System of manifolds and gauges allowing for the simultaneous connection of the cylinders to the main circuit connecting to the kiln, via a pressure regulator and an automatic control panel;
- Vacuum pump to fully recover the gas from the cylinders;
- Filter system to recover and separate oil containing gas mixtures, to avoid clogging of the system;
- Insulating material to cover piping and ensure temperature control;
- Hoist system for cylinders.

0.5” piping will be used to inject ODS into the primary air fan of the kiln burner. It is important to note that the injection of these gases should only take place once the kiln has reached a stable

operating condition and an emergency valve will be placed close to the entry point for automatic cut-off, should there be any unexpected interruptions in the operation of the kiln.

The dosage of gases injected into the kiln will take place according to the concentration of CFC present in the feedstock flux, in such a way that the stable operation and quality of the clinker will not be affected.

The following diagrams illustrate the intended set-up of the system, as well as the parts required and were developed based on information and recommendations provided by Japan.

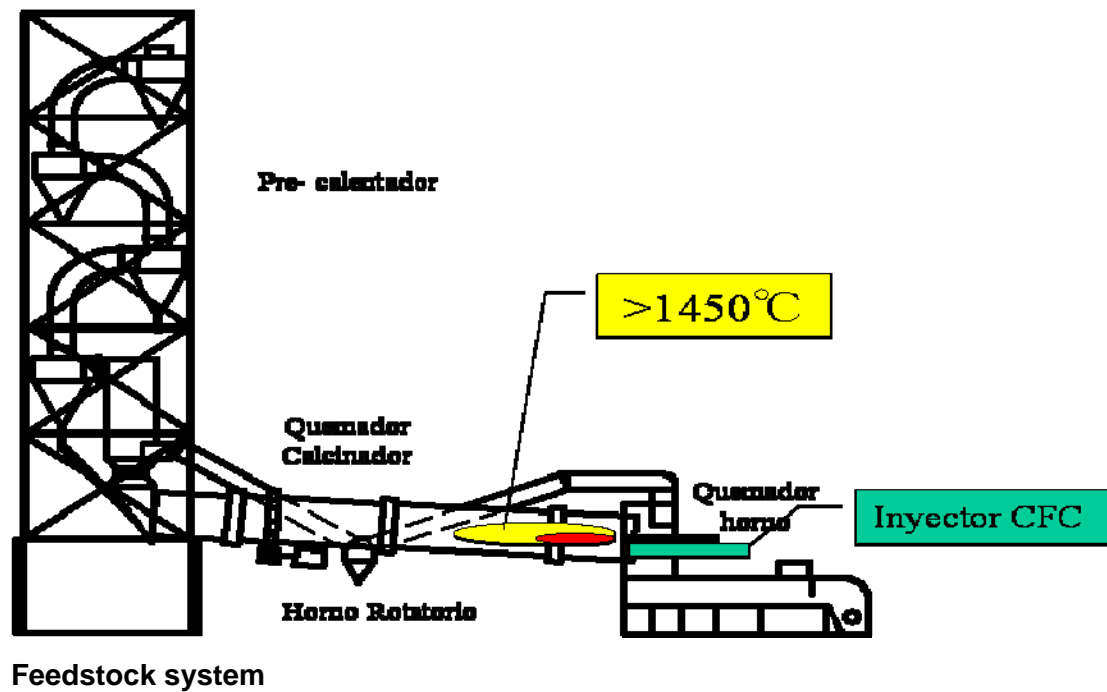

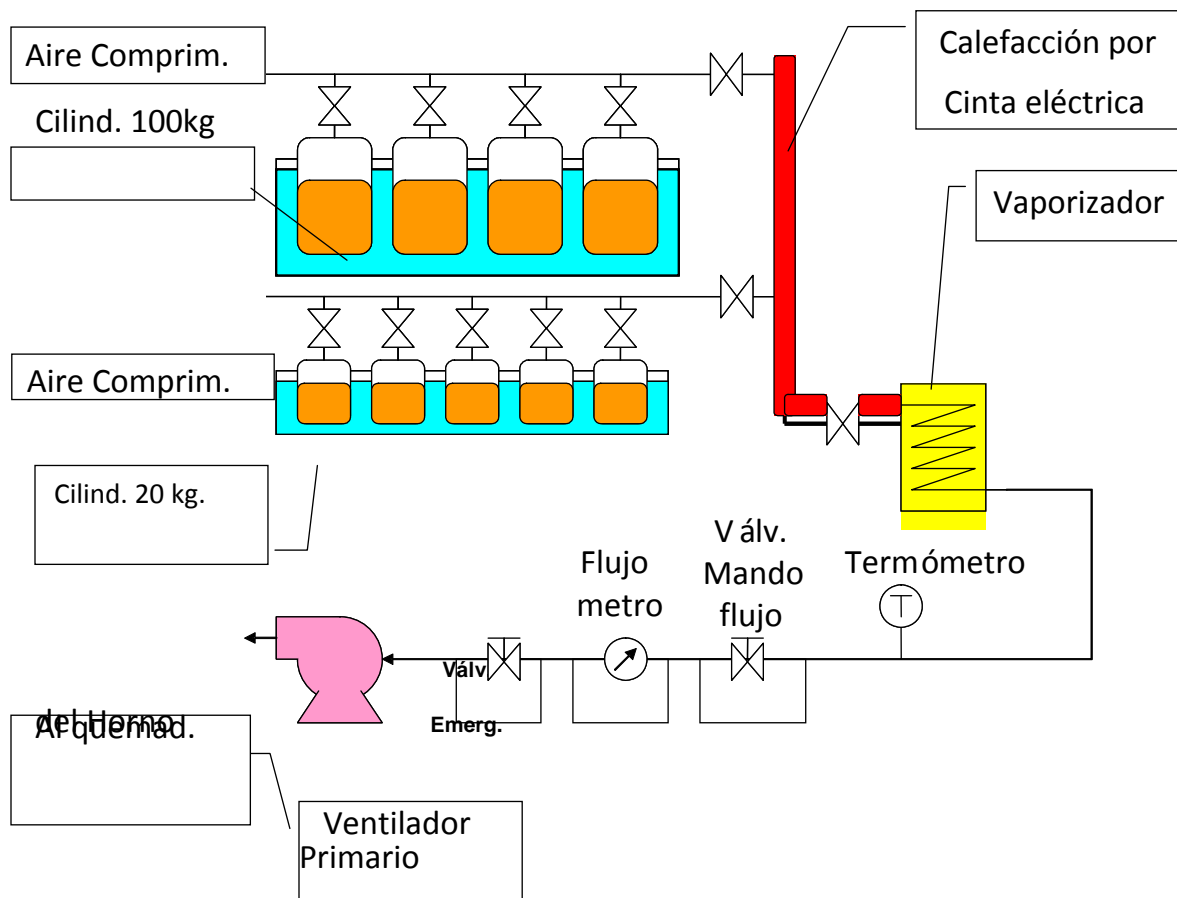

	Components	Quantity
1	Emergency shut off valve	2
2	Flow control valves	2
3	Flux meter	2
4	Air filters	2
5	Two stage vacuum pump	1
6	Hot water pump	1
7	Temperature regulating valves for the warm water baths	3
8	Automatic electric switching valves (line changes)	7
9	Ball valves (cylinder connectors)	60

10	Hoses (cylindre connectors)	30
11	Rail for transport of cylinders	1
12	Ball valves for refrigerant, degassing and vapour	9
13	Valves for general maintenance	13
14	Control valve for entry point into feedstock line	1
15	Valves for entry point into circulation line	2
16	Ball valve for entry point into vaporizing chamber	1

Total cost of the disposal activity including costs not covered by the Multilateral Fund and, the sources of funding for covering these costs

The total collection, transport, dismantling, recovery and the destruction cost of CFC-12 and HCFC-22 using the cement kiln technology have been estimated in this document to be of approximately US\$400,000 for the government of Cuba and of US\$525,200 for the MLF plus 39,390 US\$ in support cost, bringing the grand total to US\$964,590. These indicative data will be verified at project implementation.

Project sustainability of the underlying business model

The MLF funding will cover the costs of implementation and operation of the pilot project for 4 years. With the expected destruction of an estimated 15.1 tons per year, this project could potentially destroy the currently stored ODS in around 8 years.

The concept of a business model is slightly different in the Cuban context as the Cement factory is a company that is owned and run by the government of Cuba and, operational expenses at the cement factory are covered by the government of Cuba (now and in the future). The costs of the services are assumed by the government of Cuba as a part of its commitment to the environment.

It is the Government of Cuba's responsibility to cover to cost of running the services and it will pay to the government enterprises that are involved in this scheme. In other words, a business model exists but the characteristics are different from what is seen in many other countries.

iii. Other sources of funding.

As mentioned throughout this document, the Government of Cuba has to date invested over 700 million US dollars to collect, manage and store the ODS intended for destruction and intends to continue supporting the recovery, collection and transport activities, as well as to continue providing support through technical expertise, storage facilities, staff (including engineers,

managers, technicians, assistants, etc.), training facilities, assembly/construction, equipment, monitoring etc. as might be required by the project.

The government of Cuba will continue to finance the operation of 80 R&R centers, as well as additional activities under the refrigerator replacement programme, (to name a few) which as described in this document, represent a huge co-financing investment from Cuba in this project

In addition, there are already around 1,000 workshops integrated into this activity, representing an estimated 5,000 technicians, 80 R&R Centers and Central Storage Facilities, and the cost of operation are financed by the country. In addition, there is currently in place a fully computerized database that is centrally controlled by EIESA. This requires equipment, IT expertise and follow up, and the database is updated regularly to take into account all of the changes and movements relative to the collection, transport and storage of ODS.

Although this investment cost is to be verified during project implementation, an initial estimate is that an amount representing no less than US\$ 400,000 will be required and provided by Cuba, to ensure provision of the above-mentioned services. This is a very low estimate provided by the government of Cuba, and the real cost is much higher.

Although as also mentioned previously Cuba would be interested in exploring this approach in the future, at present in practical terms there are no voluntary market options for Cuba. However it is important to note that the energy savings achieved from the decommissioning of energy-inefficient units has allowed for large reductions in consumption of fossil fuels on an annual basis, and has in addition liberated thermoelectric generation capacity which is vital for the development of the country.

UNDP is actively working on looking for alternative sources of funding for carbon credits, and this strategy is actively being pursued in other ODS Waste Management Demonstration projects. However, in the context of the current proposal for Cuba this is currently not seen as a viable option in the short run. Cuba is still in the initial phases of exploring the potential of accessing Carbon Markets and is willing to further explore this option in the future, however the country does not want to make project success dependant on factors that are completely out of its control. Exploring the option that carbon markets could potentially co-finance future operations of the ODS waste management in Cuba, once the demonstration project has been completed, will however be pursued.

iv. Concept for monitoring the origin of recovered ODS

In order to guarantee the accurate and almost “real-time” monitoring of the Cuban implemented *National Total Substitution Programme for High-Energy Consuming, ODS Based Refrigerators and Air Conditioners*, the government implemented a detailed and stringent compulsory monitoring and verification plan. This not only to avoid double counting and error but more particularly to guarantee the traceability and chain of custody of the recovered units, the ODS they contained and their transport towards a storage facility.

This system will form the basis of the monitoring system which will be further reinforced and adapted to follow the ODS all the way from their current point of storage to their ultimate destruction, both for destruction using the rotary cement kiln technology, as well as for that using the plasma arc technology.

v Assurances that the amount of ODS mentioned will actually be destroyed.

These assurances will be provided and backed up by the registry held in the destruction facilities which will have to match that of the central storage facilities and which will, in addition, be backed up by the certificates provided to the enterprises from which ODS have been picked up.

The Cement Company is responsible for the destruction of the ODS in the cement kiln. Each month it must submit an official report to the CITMA (Ministry of Science, Technology and Environment) and annually to the National Statistics Office. The Center for Environmental Inspection and Control is the unit that will carry-out frequent audits to assure that actual ODS quantities have been disposed of in an environmentally sound manner. The national ozone unit will also conduct periodic inspections at the cement plant destruction facility.

The proposed activities at the cement facility have been elaborated by officials from the government of Japan and would allow Cuba to comply with international standards

An additional source of information will be the registry from the automatic injection facility to be set up at the kiln, as well as the registry of use from the plasma arc machine, which can also be correlated with actual produced quantities of cement.

vi Exploration of other disposal options for the used ODS.

Although other options were studied, including transporting these ODS for destruction abroad (for which initial estimates prepared by Cuba showed that price to destroy over 260 tons ranged in the 2.5 to 3 million dollars), as well as burning these in the flaring towers (not allowed for under the UNFCCC), the only viable alternatives for the country were the ones detailed throughout the document.

More importantly, the costs of destruction of the current stock should not be compared with the cost of the start up activities in Cuba for the simple reason that the two things aim at doing different things. Exporting all ODS waste would eliminate Cuba's current problem with ODS waste but there would be no installed capacity at the local level to deal with future stocks of recovered ODS waste. On the contrary, the suggested project would install national capacity that would allow Cuba to deal with ODS waste not only now, but also in the future.

4. PROJECT COSTS

Table-4: Project Budget – cost estimation

Tasks	Activity	# Units	US\$/Unit	Cost	Purpose
General					
Local Transportation	Specialized equipment for local transport ODS Waste in Cuba (1000 workshops -> 169 Municipal centers -> 80 R&R Centers -> Central Storage Facilities -> Final Disposal). Including adaptation of vehicles.			70,000	Transport
Operating Costs Disposal Centre	Manager (3 years)	As required		Government contribution	
	Assistant (3 years)	As required		Government contribution	
	Rental of space	As required		Government contribution	
	Office Equipment (Including computers for monitoring)			10,000	Monitoring
	Running costs (water, electricity)	As required		Government contribution	
	Industrial Recovery machines (transfer ODS waste between cylinders), ancillary equipment, associated tools, ODS identifiers, materials, etc.	6		60,000	Transport & Storage
	Temporary storage cylinders at the 1000 workshops.	1000	80	80,000	Storage
Capital Costs - Cement Kiln Technology					
	Automatic control panel for 2 kilns	1	70,000	70,000	Destruction
	Equipment, including gauges (high pressure, low pressure), flow valves, regulators, manifolds (high and low pressures), air and oil filters, electronic speed flow transmitter, electronic combustion gas analyzer	1	122,000	122,000	Destruction
	Electrical components, including cables, switches, tubing, supports, switch boxes, control panel, etc.	1	5,000	5,000	Destruction
	Hydraulic components, including heating elements, gas cylinders, relief valves, manifolds, gauges, supports, inox steel tubing, electronic weighing scale, portable gas identifier, etc.	1	35,000	35,000	Destruction

	Labour costs for design and construction of sites	As required		Government Contribution	
	10 % contingency		23,200	23,200	
Assistance and Outreach					
Technical Assistance	Technology Transfer, Training (International Consultant)		30,000	30,000	Destruction
Outreach and Monitoring	Workshops to share information with other countries in the region and System to control/monitor use and movements of empty/full cylinders, identifiers gas chromatography			20,000	Outreach and Monitoring
Total				525,200	

On behalf of the Government of Cuba, UNDP requests a grant for the first phase of this project amounting to

Project Cost - US\$ 525,200

Support Cost (7,5 %) - US\$ 39,390

Total Cost - US\$ 564,590

IMPLEMENTATION/MONITORING**Table-5: Implementation Schedule**

TASKS	2011				2012							
	1 Q	2 Q	3 Q	4 Q	1 Q	2 Q	3 Q	4 Q	1 Q	2 Q	3 Q	4 Q
MF Project Approval (end 2010)												
Receipt of Funds	X											
Grant Signature		X										
Project Start-up		X										
Procurement arrangements		X										
Arrival of equipment			X	X								
Phase I – Training and trials												
Arrival of parts and set up of kiln facility			X									
Arrival of Plasma machine and chemicals				X								
- Training by supplier				X								
- Trial and Testing					X							
Analysis/Reporting/preparation phase II						X						
Phase II - Operation												
Operation						X	X	X	X	X	X	X
Mid term and final Analysis/Reporting								X			X	
Final report												X

Table-6: MILESTONES FOR PROJECT MONITORING

TASK	MONTH*
Project document submitted to beneficiaries	2
Project document signatures	4
Procurement of technologies	6
Phase I – Modifications to cement kiln and testing	7
Testing/analysis/reporting	7
Phase II – start of full scale operations	7
Phase I – Training and trial runs Plasma machine and chemicals delivered	8
Training and Trial Runs	9
Testing/analysis/reporting	10
Phase II – start of full scale operations	12
Mid-term review – analysis/reporting	24
Phase II project closure – final reporting	48

* From project approval

From experience, demonstration projects normally take more time than what was initially foreseen. One good example is the successful Chillers demonstration project.

In the beginning there will be a period of initial investment and installation. Then trials and start up will follow. The continued verification and monitoring of the processes are important in order to maximize the efficiency of the system while minimizing the possibility of damage to the equipment. Some time would also be needed to destroy a reasonable quantity of ODS waste. It should be possible to share initial results after 1-2 year with other countries in the region but the continued operation of the system is important to make the necessary adjustments and fine-tuning that would help to ensure the long term, cost-effective and risk free operation of the system.

This not only applies for the destruction of ODS, but it is equally important for the logistics related to the ODS management (transport, storage, etc.) system in Cuba.

6. Appendixes

Appendix 1: Transmittal Letter

Appendix 2: Quotation from ASADA Corporation

Appendix 1: Transmittal Letter

Appendix 2: Quotation from ASADA Corporation



3-60 KAMIIDA NISHI-MACHI, KITA-KU,
NAGOYA, 462-8551 JAPAN
TEL: (81)52-914-1206, FAX: (81)52-914-2011

Dear DR. NELSON ESPINOSA
DIRECTOR, OFICINA DE OZONO DE CUBA

Date; August 6, 2010

Ref. _____

QUOTATION #2

	<u>Unit Price</u>
1) Recovery Machine	
Model Eco Saver Tetra, 100V-120V with Std Acc	
C&F Havana with Plasma >	<u>\$3,790.00</u>
Model ECO Saver R350 100V-120V with Std Acc	
C&F Havana with Plasma >	<u>\$8,200.00</u>
2) Piercing Valve(#TF014)	
C&F Havana with Plasma >	<u>\$166.00</u>
3) Header	
With Valve (#TF039)	
C&F Havana with Plasma >	<u>\$133.00</u>
Without Valve(#TF01)	
C&F Havana with Plasma >	<u>\$74.00</u>

Bankers: MIZUHO BANK, LTD. NAGOYA-CHUO BRANCH
3-4-5 SAKAE NAKA-KU, NAGOYA, JAPAN
THE BANK OF TOKYO-MITSUBISHI UFJ, LTD. HIGASHI BRANCH
1-15-30 TOKUGAWA, HIGASHI-KU, NAGOYA, JAPAN